

PLC DATA SHEET

Product: IC693MDL648 Discrete Input Module

48 Volt DC, 16 Point, Positive/Negative Logic

Product Description

This **48 volt DC Positive/Negative Logic Input** module for the IC693-Series Programmable Logic Controller provides 16 input points in one group with a common power input terminal. *The on and off response times for this module are 1 mSec maximum.* This input module is designed to be used in either positive logic or negative logic applications. Input characteristics are compatible with a wide range of user-supplied input devices, such as pushbuttons, limit switches, and electronic proximity switches. Current flow into an input point results in a logic 1 in the PLC input status table (%I). Power to operate input devices must come from an external power 48 VDC source supplied by the user.

LED indicators that provide the ON/OFF status of each point are located at the top of the module. This LED block has two horizontal rows with eight green LEDs in each row; the top row is labeled A1 through 8 (points 1 through 8) and the bottom row is labeled B1 through 8 (points 9 through 16). An insert fits between the inside and outside surface of the module's hinged cover. The back of the insert has circuit wiring information, and circuit identification information can be written on the front of the insert. The front left edge of the insert is color-coded blue to indicate a DC-type module. This module can be installed in any I/O slot of a 5 or 10-slot baseplate in an IC693-Series PLC system.

Table 1. Specifications for IC693MDL648

Rated Voltage	48 volts DC
Input Voltage Range	0 to 60 volts DC
Inputs per Module	16 (one group with a single common)
Isolation	1500 volts between field side and logic side
Input Current	4.2 mA (typical) at rated voltage
Input Characteristics	
On-state Voltage	34 to 60 volts DC
Off-state Voltage	0 to 10 volts DC
On-state Current	3 mA minimum
Off-state Current	1.1 mA maximum
On response Time	1 ms maximum
Off response Time	1 ms maximum
Power Consumption: 5V	80 mA (all inputs on) from 5 volt bus on PLC backplane
Power Consumption: 48V	74 mA from the user-supplied 48VDC power supply

Refer to data sheet GFK-0867 for product standards and general specifications.

IC693MDL648 Input Module Field Wiring Information

The following figure provides wiring information for connecting user-supplied input devices and power source to the 48 volt DC positive/negative logic input module.

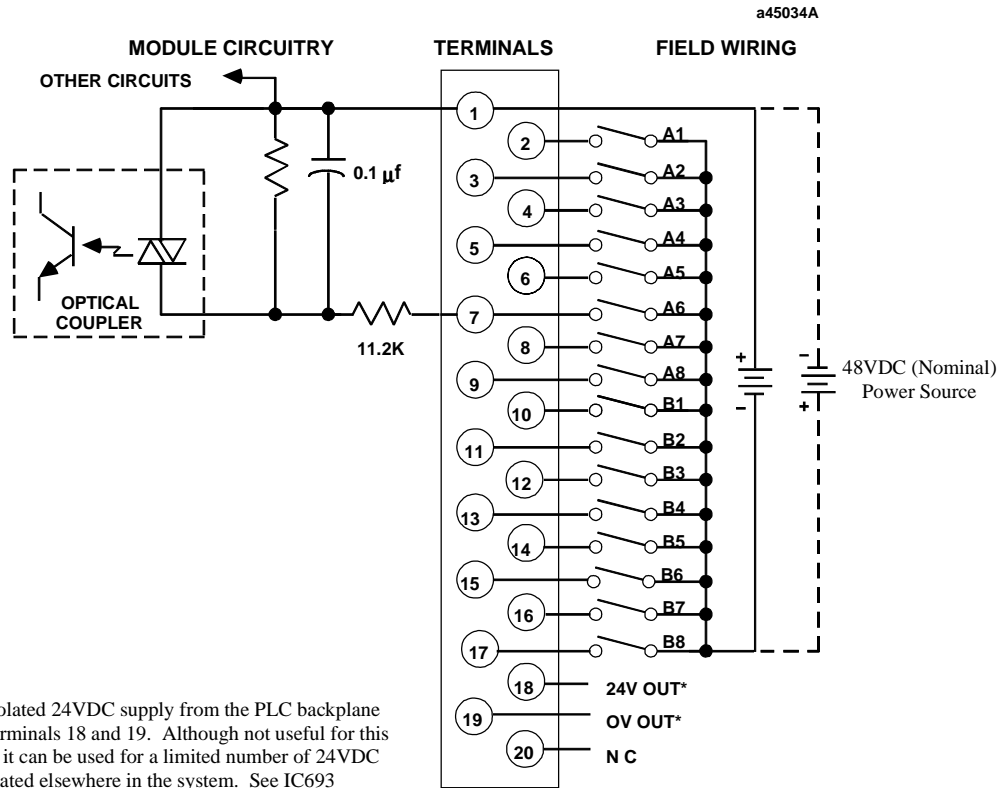

Figure 1. Field Wiring – 48 Volt DC Pos/Neg Logic Input Module – IC693MDL648

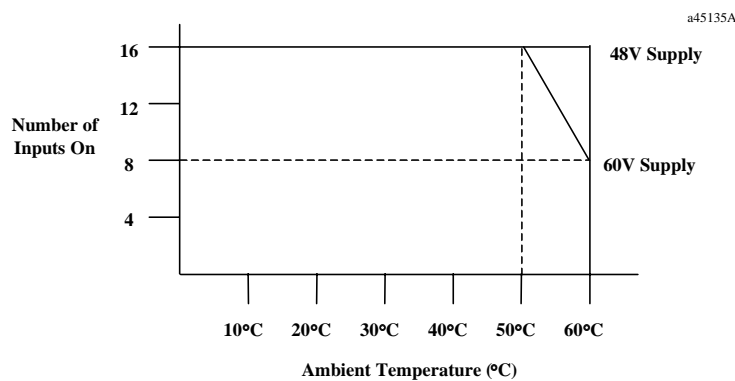

Figure 2. Input Points vs. Temperature for IC693MDL648

Configuration Information

Check to see if the module catalog number, IC693MDL648, is found in your configuration software's Input Module list. If so, select it from the list; if it is not listed, configure it as a Generic 16-circuit (16-point) Discrete Input Module.